

CROE EXHAUST GAS CLEANING SYSTEMS

THE EMISSIONS
SOLUTION

CROE IN-LINE SCRUBBER
BOTTOM INLET

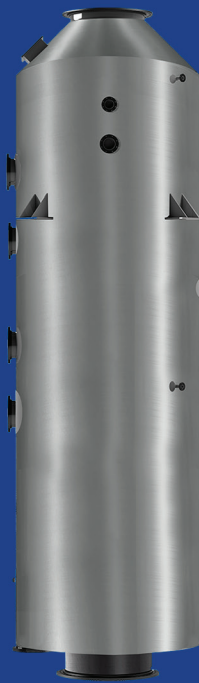

CROE OFF-LINE SCRUBBER
SIDE INLET



CROE U-TYPE SCRUBBER

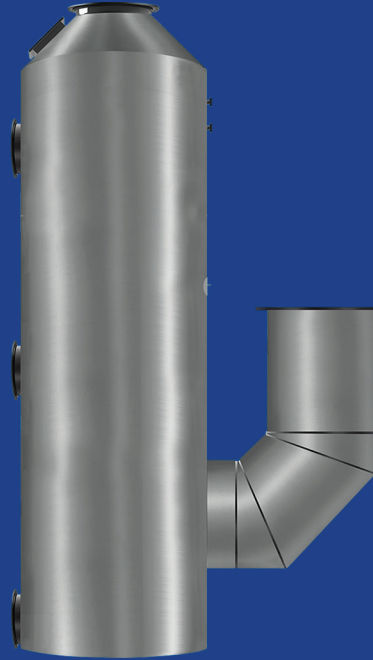

0.1% AND 0.5% SULFUR EQUIVALENCY TO MEET IMO COMPLIANCE REQUIREMENTS WITHOUT THE HIGH PRICES OF LOW SULFUR FUELS.

MARPOL ANNEX VI stringent, regulations for vessels operating in the Emission Control Areas (ECAs) in **North America and North Sea/Baltic** present formidable challenges for ship owners who now face higher prices, low availability and operating difficulties.

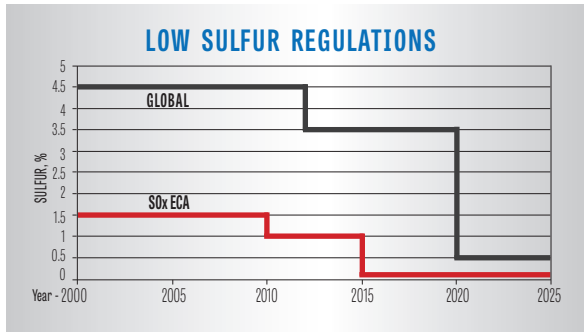

USING SCRUBBERS WHILE BURNING RESIDUAL FUELS COULD HELP REDUCE GLOBAL CO₂ LEVELS: NEW NORWEGIAN STUDY

“The continued use of heavy fuel oil with an exhaust gas cleaning system (EGCS) is the most environmentally beneficial means of meeting global greenhouse gas (GHG) emissions targets, Chief Scientist Dr. Elizabeth Lindstad concluded in a study published by Norway’s SINTEF.”

World Maritime News

Ship owners, however, enjoy an alternative path to compliance by using the CROE exhaust gas cleaning scrubbers. **CR Ocean Engineering’s Exhaust Cleaning Systems** do the job, providing an assurance of meeting the 0.1% or 0.5% sulfur fuel equivalency when burning high-sulfur fuels. This means you will be fully compliant at a fraction of the cost.

IDEAL FOR CRUISE SHIPS, FERRIES, BULK CARRIERS, CONTAINER SHIPS, RORO AND OTHERS FOR RETROFIT AND NEW BUILD SHIPS.

CE DELFT SCRUBBER WASHWATER STUDY SHOWS MINIMAL IMPACT

“Preliminary results of an independent study presented by CE Delft, a research organisation in the Netherlands specialising in environmental issues, indicating that accumulated concentrations of exhaust gas cleaning systems (EGCS, or ‘scrubbers’) wash water components are at very low levels and well below applicable regulatory limits have been welcomed by The Clean Shipping Alliance (CSA) 2020.”

ShipInsight

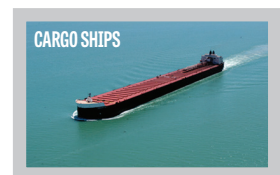

THREE STANDARD DESIGNS. FOR SINGLE ENGINE OR FOR MULTI-STREAMING OPERATIONS. RETROFITS OR NEW BUILD SHIPS.

AVAILABLE IN THREE STANDARD DESIGNS TO MEET YOUR SHIP'S REQUIREMENTS.

The **CR Ocean Engineering** ship exhaust gas cleaning technology is available in three standard configurations, customizable to a ship's requirements:

- ▶ **OPEN-LOOP:** once through scrubber using seawater
- ▶ **CLOSED-LOOP:** a recirculating scrubber using freshwater with caustic
- ▶ **HYBRID:** a combination of both designs for maximum flexibility



CR OCEAN ENGINEERING SCRUBBERS OFFER THE FOLLOWING FEATURES AT COMPETITIVE PRICES:

- **Bottom entry or side entry designs** to allow a direct up-flow configuration and simplify engine exhaust gas duct routing for any type of vessel.
- **All CROE designs can operate with or without bypass.**
- Strategically configured exhaust gas inlet and scrubber drainage to eliminate any potential water backflow to the engine.
- **Eliminated circulation water storage** from bottom of scrubber vessel to a separate tank at a lower elevation to reduce weight at the higher elevations, improving stability.
- **Metallic construction** (external and internal) to extend the life of the system and allow the exhaust gas to travel through the scrubber system in dry conditions, without a bypass in areas of the world where scrubbing is not yet needed.
- Used **proprietary internals** designed specifically to increase contact area with lower liquid flows to save on typical pumping costs associated with some scrubber designs.
- **Proprietary Caustic-Assist™** feature for **Open-Loop Assist** operating in low-alkalinity areas.



CR Ocean[®]
Engineering

THREE STANDARD DESIGNS. FOR SINGLE ENGINE OR FOR MULTI-STREAMING OPERATIONS. RETROFITS OR NEW BUILD SHIPS.

WE MEET YOUR MARITIME EMISSIONS CHALLENGES

Visit us at: **croceanx.com**

Email Dominique Philibert at
dphilibert@croceanx.com

Call us at:

+ 1 (973) 455-0005, EXT. 123

